

Архангельск (8182)63-90-72
Астана +7(7172)727-132
Белгород (4722)40-23-64
Брянск (4832)59-03-52
Владивосток (423)249-28-31
Волгоград (844)278-03-48
Вологда (8172)26-41-59
Воронеж (473)204-51-73
Екатеринбург (343)384-55-89
Иваново (4932)77-34-06
Ижевск (3412)26-03-58
Казань (843)206-01-48

Калининград (4012)72-03-81
Калуга (4842)92-23-67
Кемерово (3842)65-04-62
Киров (8332)68-02-04
Краснодар (861)203-40-90
Красноярск (391)204-63-61
Курск (4712)77-13-04
Липецк (4742)52-20-81
Магнитогорск (3519)55-03-13
Москва (495)268-04-70
Мурманск (8152)59-64-93
Набережные Челны (8552)20-53-41

Нижний Новгород (831)429-08-12
Новокузнецк (3843)20-46-81
Новосибирск (383)227-86-73
Орел (4862)44-53-42
Оренбург (3532)37-68-04
Пенза (8412)22-31-16
Пермь (342)205-81-47
Ростов-на-Дону (863)308-18-15
Рязань (4912)46-61-64
Самара (846)206-03-16
Санкт-Петербург (812)309-46-40
Саратов (845)249-38-78

Смоленск (4812)29-41-54
Сочи (862)225-72-31
Ставрополь (8652)20-65-13
Тверь (4822)63-31-35
Томск (3822)98-41-53
Тула (4872)74-02-29
Тюмень (3452)66-21-18
Ульяновск (8422)24-23-59
Уфа (347)229-48-12
Челябинск (351)202-03-61
Череповец (8202)49-02-64
Ярославль (4852)69-52-93

www.barthel.nt-rt.ru || bet@nt-rt.ru

ШЛАНГИ, ТРУБЫ

Каталог Barthel Armaturen

Arten von Prüfbescheinigungen nach EN 10204:2005

Test certificates according to EN 10204:2005

ab April 2005

Prüfbescheinigung <i>test report</i>	Aussteller <i>Person in charge</i>	Inhalt der Bescheinigung <i>certified results</i>
Werksbescheinigung 2.1 <i>Works report 2.1</i>	Hersteller (Vertrieb) manufacturer (sales dept.)	Keine Angaben von Prüfergebnissen. Bescheinigung, dass die gelieferten Erzeugnisse den Anforderungen der Bestellung entsprechen. <i>No information about test results attesting that the delivered goods correspond with the order.</i>
Werkszeugnis 2.2 <i>Works test report 2.2</i>	Hersteller (Vertrieb) manufacturer (sales dept.)	Prüfergebnisse <u>nichtspezifischer Prüfungen</u> . Bescheinigung, dass die gelieferten Erzeugnisse den Anforderungen der Bestellung entsprechen. <i>Test results of non-specific tests attesting that the delivered goods correspond with the order.</i>
Abnahmeprüfzeugnis 3.1 <i>Inspection certificate 3.1</i>	Abnahmebeauftragter des Herstellers(Prüfaufsicht) <i>Test supervisor of manu- facturer</i>	Prüfergebnisse <u>spezifischer Prüfungen</u> Bescheinigung, dass die gelieferten Erzeugnisse den Anforderungen der Bestellung entsprechen. <i>Test results of specific tests attesting that the delivered goods correspond with the order.</i>
Abnahmeprüfzeugnis 3.2 <i>Inspection certificate 3.2</i>	Abnahmebeauftragter des Herstellers(Prüfaufsicht) und/oder dem in amtlichen Vorschriften genannten Abnahmebeauftragten <i>Test supervisor of manu- facturer and/or test supervisor nominated as per official regulations</i>	Prüfergebnisse <u>spezifischer Prüfungen</u> Bescheinigung, dass die gelieferten des Bestellers Erzeugnisse den Anforderungen der Bestel- lung entsprechen. <i>Test results of specific tests attesting that the delivered goods correspond with the order.</i>

Gegenüber DIN EN 10204:1995-08 wurden folgende Änderungen vorgenommen:

Compared to DIN EN 10204:1995-08 the following alterations have been made:

- a) Einführung neuer Begriffe „Hersteller“, „Händler“ und „Erzeugnisspezifikation“
- a) *establishment of the new definitions: manufacturer, trader and product specification*
- b) - Streichung des Werkszeugnisses 2.3 der früheren Ausgabe
- Abnahmeprüfzeugnis 3.1 ersetzt 3.1.B der früheren Ausgabe
- Abnahmeprüfzeugnis 3.2 ersetzt 3.1.A, 3.1.C und 3.2 der früheren Ausgabe
- b) - *annulation of test report 2.3 of former edition*
- *test report 3.1B of former edition replaced by test report 3.1*
- *test report 3.1.A, 3.1.C and 3.2 of former edition replaced by test report 3.2*
- c) Änderung der deutschen Bezeichnung „Sachverständiger“ in „Abnahmebeauftragter“
- c) *alteration of the German name „expert“ into „test supervisor“*

**Internationale Normen/
international standards DN - NPS PN - CL (Class)**

Nennweite/ <i>nominal diameter</i>		Nenndruck/ <i>nominal pressure</i>		Prüfdruck/ <i>test pressure</i>	Betriebsdruck/ <i>working pressure</i>
DN	NPS	PN	CL	PT	PS₂₀
6	1/8	6	/	10	6
8	1/4	10	/	16	10
10	3/8	/	125	18	12
15	1/2	16		25	16
20	3/4	/	150	30	20
25	1	25	/	40	25
32	1 ¼	/	250	42	28
40	1 ½	40	/	60	40
50	2	/	300	78	50
65	2 ½	63	/	96	63
80	3	/	400	104	68
100	4	100	/	150	100
125	5	/	600	154	100
150	6	/	900	230	150
200	8	160	/	240	160
250	10	250	/	375	250
300	12	/	1500	383	250
350	14	320	/	480	320
400	16	400	/	600	400
500	20	/	2500	639	420
600	24	↓			

EN 1333

↓
PN = Kenngrößensystem Alphanumerische
Kenngröße für Referenzzwecke

*characteristic quantity system alpha-numeric
characteristic quantity for references*

EN ISO 6708

↓
DN = Alphanumerische Bezeichnung für Referenzzwecke (kennzeichnet die Größe für Bauteile in einem Rohrleitungssystem)
alpha-numeric nomenclature for references (for identification of sizes for construction units in pipeline systems)

Gewindearten types of threads

Gewinde nach EN 10226-1 ↔ ISO 7/1
Threads according to EN10226-1 ↔ ISO 7/1
(Ersatz für DIN 2999 T1)

R - Gewinde ⇒ außen kegelig
R - threads ⇒ outside conical
⇒ innen zylindrisch **Rp** (parallel)
⇒ inside cylindric **Rc** (conical)

für Rohre und Verschraubungen, die im Gewinde gedichtet werden.

For pipes and fittings which are seated inside of the threads.

Verwenden von Dichtmitteln (z.B. PTFE-Band).

Use of sealing material (e.g. PTFE-tape)

Flankenwinkel = 55°
angle of screw thread = 55°

Gewinde nach ISO 228/1 (alt = DIN 259 T1)
Threads according to ISO 228/1 (former DIN 259 T1)

G - Gewinde ⇒ außen zylindrisch
G - thread ⇒ outside cylindric
⇒ innen zylindrisch
⇒ inside cylindric

für druckdichte Verbindungen,
die nicht im Gewinde gedichtet werden/*for pressure safe connections which are not to be seated in the inside of the threads.*

Verwenden von Dichtringen

Use of sealing rings

Flankenwinkel = 55°
angle of screw thread = 55°

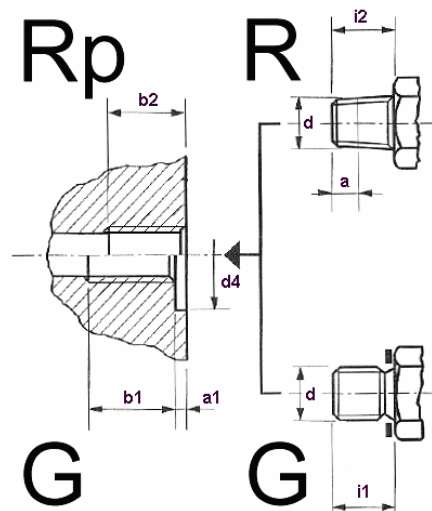

Größe/ size	Gangz./Zoll threads/unit	d	a	i2		b2		i1		b1		d4		a1	
				DIN 3852 T2	DIN 3852 T2	DIN 3852 T2	DIN 3852 T2	DIN 3852 T2	DIN 3852 T2	DIN 3852 T2	DIN 3852 T2				
1/8	28	9,7	4,0	6,5	5,5	8	8	15	1						
1/4	19	13,2	6,0	10	8,5	12	12	19	1,5						
3/8	19	16,7	6,4	10	8,5	12	12	23	2						
1/2	14	21,0	8,2	12	10,5	14	14	27	2,5						
3/4	14	26,4	9,5	14	13	16	16	33	2,5						
1	11	33,3	10,4	14	14	18	18	40	2,5						

Gewinde nach ANSI B1.20.1 (alt = ASA B2.1)
threads according to ANSI B1.20.1 (former ASA B2.1)

NPT - Gewinde ⇒ außen konisch
NPT - threads ⇒ outside conical
⇒ innen konisch
NPT - threads ⇒ inside conical

für druckdichte Gewindeverbindungen,
die im Gewinde gedichtet werden.
for pressure-tight thread connections which are to be seated in the inside of the threads

Verwenden von Dichtmitteln (z.B. PTFE-Band)

Use of sealing material (e. g. PTFE-tape)

Flankenwinkel = 60°
angle of screw thread = 60°

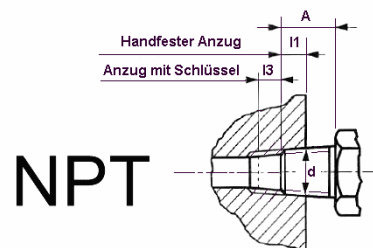

Größe/ size	Gangz./Zoll threads/unit	d	> A	l1	l3
			ASA B16.11		
1/8	27	10,2	9,5	4,6	2,8
1/4	18	13,5	11,1	5,1	4,2
3/8	18	17,3	12,7	6,1	4,2
1/2	14	21,1	14,3	8,1	5,4
3/4	14	26,4	15,9	8,6	5,4
1	11 1/2	33,1	19,1	10,2	6,6

Werkstoffnummern Stahl
material no. steel

Werkstoff Nr. <i>material No.</i> [neu - alt] [new - former]	Kurzbenennung <i>short form</i> [neu] [new]	Kurzbenennung <i>short form</i> [alt] [former]	Hinweis <i>advice</i>
0.6025	EN-JL1040	EN-GJL-250	GG-25 - Lamellengraphit
0.7043	EN-JS1025	EN-GJS-400-18-LT	GGG-40.3 - Kugelgraphit
1.0038	S235JRG2	RSt 37-2	
1.0254	P235TR1	St 37.0	
1.0255	P235TR2	St 37.4	
1.0345 - 1.0305	P235GH	St 35.8	
1.0425 - 1.0405	P265GH	St 45.8	
1.0425	P265GH	H II	
1.0432	C21	C21	A105
1.0460	P250GH	C 22.8	
1.0501	C35	C35	
1.0503	C45	C45	
1.0566	P355NL1	TStE 355	
1.0570	S355J2G3	St 52-3	
1.0581	P355T2	St 52.4	
1.0619	GP240GH	GS-C 25	Stahlguss/cast steel
1.0715	11SMn30	9SMn28	AZ
1.1181	2C35	Ck35	
1.1200	Federstahl DH	Federstahl C/D	FB intern/internal
1.4016	X6Cr17	X6Cr17	
1.4021	X20Cr13	X20Cr13	
1.4057	X17CrNi16-2	X20CrNi17 2	
1.4104	X14CrMoS17	X12CrMoS17	
1.4301	X5CrNi18-10	X5CrNi18 10	
1.4305	X8CrNiS18-9	X10CrNiS18 9	
1.4310	X10CrNi18-8	X12CrNi17 7	
1.4401	X5CrNiMo17-12-2	X5CrNiMo18 10	
1.4404	X2CrNiMo17-12-2	X2CrNiMo18 10	
1.4435	x2CrNiMo18-14-3	X2CrNiMo18 12	
1.4439	X2CrNiMoN17-13-5	X2CrNiMoN17 13 5	
1.4462	X2CrNiMoN22-5-3	X2CrNiMoN22 5	
1.4539	X1NiCrMoCuN25-20-5	X2NiCrMoCu25 20 5	
1.4541	X6CrNiTi18-10	10CrNiTi 18 9	V2A
1.4571	X6CrNiMoTi17-12-2	X10CrNiMoTi 18 10	V4A
1.4762	X10CrAlSi25	X10CrAl24	
1.4841	X10CrMoVNb9-1	X10CrMoVNb9-1	
1.4873	X45CrNiW18-9	X45CrNiW18-9	
1.4878	X12CrNiTi18-9	X 12 CrNiTi 18 9	
1.4903	X10CrMoVNb9-1	X10CrMoVNb9-1	
1.5415	16Mo3	15 Mo 3	
1.5680	12Ni19	12Ni19	
1.7258	24CrMo5	24 CrMo 5	Mutter/nut
1.7335	13CrMo4-5	13 CrMo 4 4	
1.7362	X11CrMo5	12 CrMo19 5	
1.7380	10CrMo9-10	10CrMo9 10	
1.7383	11CrMo9-10		
1.7709	21CrMoV5-7	21 CrMoV 5 7	Schraube/screw

Werkstoffnummern NE-Metalle
material no. non-ferrous metals

Werkstoff Nr. Material No. [neu - alt] [new - former]	Kurzbenennung short form [neu] [new]	Kurzbenennung short form [alt] [former]	Hinweis advice
2.0090	CW024A	Cu-DHP	SF-Cu Kupfer/copper
2.0335	CW507L	CuZn36	Ms63/brass 63
2.0401	CW614N	CuZn39Pb3	Ms58/brass58
2.0402	CW617N	CuZn40Pb2	Ms58/brass58
2.0460	CW702R	CuZn20Al2As	SoMs76/spec.brass
2.0540	CW710R	CuZn35Ni3Mn2AlPb	SoMs59 (EO)spec.br.
2.0872	CW352H	CuNi10Fe1Mn	CuNi/copper-nickle
2.0882	CW354H	CuNi30Mn1Fe	CuNi/copper-nickle
2.0966	CW307G	CuAl10Ni5Fe4	Alu Bronze/bronze
2.0975	CC333G-GS	CuAl10Fe5Ni5-C-GS	G-CuAl10Ni
2.1020	CW452K	CuSn6	SnBz6 / Zinnbronze
2.1030	CW453K	CuSn8	SnBz8 / Zinnbronze
2.1050	CC480K-GS	CuSn10-C-GS	GBz10
2.1052	CC483K	CuSn12-C	GBz12
2.1090	CC493K	CuSn7Zn4Pb7-C	Rg7/gunmetal
2.1096	CC491K	CuSn5Zn5Pb5-C	Rg5/gunmetal
2.1504			WL 2.1504 - Luftfahrt
2.1972		CuNi10Fe1,6Mn	WL 2.1972 - Luftfahrt
2.4360		NiCu30Fe	Monel 400
2.4600		NiMo29Cr	Hastelloy B3
2.4610		NiMo16Cr16Ti	Hastelloy C4
2.4617		NiMo28	Hastelloy B2
2.4669		NiCr15Fe7TiAl	Inconel X-750
2.4819		NiMo16Cr15W	Hastelloy C276
3.1645	EN AW-2007	EN AW-Al Cu4PbMgMn	AlCuMgPb
3.2315	EN AW-6082	EN AW-Al Si1MgMn	AlMgSi1
3.3206	EN AW-6060	EN AW-Al MgSi	AlMgSi0,5
3.3261	EN AC-51400	EN AC-AlMg5(Si)	G-AlMg5Si
3.3535	EN AW-5754	EN AW-Al Mg3	AlMg3
3.3547	EN AW-5083	EN AW-Al Mg4,5Mn0,7	Al Mg4,5Mn
3.3561	EN AC-51300	EN AC-AlMg5	G-AlMg5
3.7025			Ti 1 - Titan 1
3.7035			Ti 2 - Titan 2

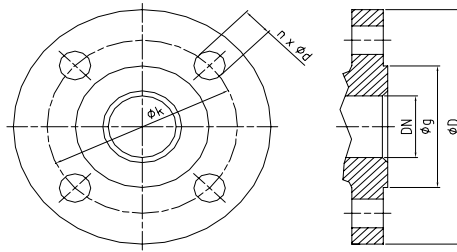

DN	PN6					PN10					PN16				
	ϕD	ϕk	n	ϕd	ϕg	ϕD	ϕk	n	ϕd	ϕg	ϕD	ϕk	n	ϕd	ϕg
10	75	50	4	11	35	90	60	4	14	40	90	60	4	14	40
15	80	55	4	11	40	95	65	4	14	45	95	65	4	14	45
20	90	65	4	11	50	105	75	4	14	58	105	75	4	14	58
25	100	75	4	11	60	115	85	4	14	68	115	85	4	14	68
32	120	90	4	14	70	140	100	4	18	78	140	100	4	18	78
40	130	100	4	14	80	150	110	4	18	88	150	110	4	18	88
50	140	110	4	14	90	165	125	4	18	102	165	125	4	18	102
65	160	130	4	14	110	185	145	4	18	122	185	145	4	18	122
80	190	150	4	18	128	200	160	8	18	138	200	160	8	18	138
100	210	170	4	18	148	220	180	8	18	158	220	180	8	18	158
125	240	200	8	18	178	250	210	8	18	188	250	210	8	18	188
150	265	225	8	18	202	285	240	8	22	212	285	240	8	22	212
200	320	280	8	18	258	340	295	8	22	268	340	295	12	22	268
250	375	335	12	18	312	395	350	12	22	320	405	355	12	26	320
300	440	395	12	22	365	445	400	12	22	370	460	410	12	26	378
350	490	445	12	22	415	505	460	16	22	430	520	470	16	26	438
400	540	495	16	22	465	565	515	16	26	482	580	525	16	30	490
500	645	600	20	22	570	670	620	20	26	585	715	650	20	33	610

DN	PN25					PN40				
	ϕD	ϕk	n	ϕd	ϕg	ϕD	ϕk	n	ϕd	ϕg
10	90	60	4	14	40	90	60	4	14	40
15	95	65	4	14	45	95	65	4	14	45
20	105	75	4	14	58	105	75	4	14	58
25	115	85	4	14	68	115	85	4	14	68
32	140	100	4	18	78	140	100	4	18	78
40	150	110	4	18	88	150	110	4	18	88
50	165	125	4	18	102	165	125	4	18	102
65	185	145	8	18	122	185	145	8	18	122
80	200	160	8	18	138	200	160	8	18	138
100	235	190	8	22	162	235	190	8	22	162
125	270	220	8	26	188	270	220	8	26	188
150	300	250	8	26	218	300	250	8	26	218
200	360	310	12	26	278	375	320	12	30	285
250	425	370	12	30	335	450	385	12	33	345
300	485	430	16	30	395	515	450	16	33	410
350	555	490	16	33	450	580	510	16	36	465
400	620	550	16	36	505	660	585	16	39	535
500	730	660	20	36	615	755	670	20	42	615

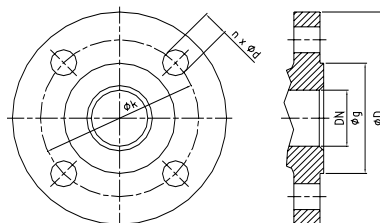

DN	JIS5KRF				JIS10KRF				JIS16KRF/20KRF			
	ØD	Øk	n	Ød	ØD	Øk	n	Ød	ØD	Øk	n	Ød
15	80	60	4	12	95	70	4	15	95	70	4	15
20	85	65	4	12	100	75	4	15	100	75	4	15
25	95	75	4	12	125	90	4	19	125	90	4	19
32	115	90	4	15	135	100	4	19	135	100	4	19
40	120	95	4	15	140	105	4	19	140	105	4	19
50	130	105	8	15	155	120	4	19	155	120	8	19
65	155	130	8	15	175	140	4	19	175	140	8	19
80	180	145	8	19	185	150	8	19	200	160	8	23
100	200	165	8	19	210	175	8	19	225	185	8	23
125	235	200	8	19	250	210	8	23	270	225	8	25
150	265	230	12	19	280	240	8	23	305	260	12	25
200	320	280	12	23	330	290	12	23	350	305	12	25
250	385	345	12	23	400	355	12	25	430	380	12	27
300	430	390	16	23	445	400	16	25	480	430	16	27
350	480	435	16	25	490	445	16	25	540	480	16	33
400	540	495	16	25	560	510	16	27	605	540	16	33
500	655	605	20	25	675	620	20	27	730	660	20	33

DN	Zoll	ANSI 150					ANSI 300				
		ØD	Øk	n	Ød	Øg	ØD	Øk	n	Ød	Øg
15	1/2	89	60	4	16	35	95	67	4	16	35
20	3/4	99	70	4	16	43	117	82,5	4	19	43
25	1	108	79	4	16	51	124	89	4	19	51
32	1 1/4	118	89	4	16	64	133	99	4	19	64
40	1 1/2	127	98	4	16	73	156	114	4	22	73
50	3	153	121	4	19	92	165	127	8	19	92
65	2 1/2	178	140	4	19	105	191	149	8	22	105
80	3	191	152	4	19	127	210	168	8	22	127
100	4	229	191	8	19	157	254	200	8	22	157
125	5	254	216	8	22	186	279	235	8	22	186
150	6	279	241	8	22	216	318	270	12	22	216
200	8	343	298	8	22	270	381	330	12	25	270
250	10	406	362	12	25	324	445	387	16	29	324
300	12	483	432	12	25	381	521	451	16	32	381
350	14	533	476	12	29	413	584	514	20	32	413
400	16	597	540	16	29	470	648	572	20	35	470
500	20	699	635	20	32	584	775	686	24	35	584

Архангельск (8182)63-90-72
 Астана +7(7172)727-132
 Белгород (4722)40-23-64
 Брянск (4832)59-03-52
 Владивосток (423)249-28-31
 Волгоград (844)278-03-48
 Вологда (8172)26-41-59
 Воронеж (473)204-51-73
 Екатеринбург (343)384-55-89
 Иваново (4932)77-34-06
 Ижевск (3412)26-03-58
 Казань (843)206-01-48

Калининград (4012)72-03-81
 Калуга (4842)92-23-67
 Кемерово (3842)65-04-62
 Киров (8332)68-02-04
 Краснодар (861)203-40-90
 Красноярск (391)204-63-61
 Курск (4712)77-13-04
 Липецк (4742)52-20-81
 Магнитогорск (3519)55-03-13
 Москва (495)268-04-70
 Мурманск (8152)59-64-93
 Набережные Челны (8552)20-53-41

Нижний Новгород (831)429-08-12
 Новокузнецк (3843)20-46-81
 Новосибирск (383)227-86-73
 Орел (4862)44-53-42
 Оренбург (3532)37-68-04
 Пенза (8412)22-31-16
 Пермь (342)205-81-47
 Ростов-на-Дону (863)308-18-15
 Рязань (4912)46-61-64
 Самара (846)206-03-16
 Санкт-Петербург (812)309-46-40
 Саратов (845)249-38-78

Смоленск (4812)29-41-54
 Сочи (862)225-72-31
 Ставрополь (8652)20-65-13
 Тверь (4822)63-31-35
 Томск (3822)98-41-53
 Тула (4872)74-02-29
 Тюмень (3452)66-21-18
 Ульяновск (8422)24-23-59
 Уфа (347)229-48-12
 Челябинск (351)202-03-61
 Череповец (8202)49-02-64
 Ярославль (4852)69-52-93